



Minimum Rules for carrying out High Voltage Live Work

This document has been developed by the VESI HV Live Work
Committee

*In the Victorian
Electricity Supply
Industry (VESI)*

August 2021

DATE	VERSION	AMENDMENT	NAME
June 2019	7	<ul style="list-style-type: none"> Section 5 added known ban tasks Section 7.2 added that the network control centre will inform the crew they are working on a REFCL feeder Section 8.5 added GFN protection settings Section 8.7 added wording. No work shall be undertaken on structures, spans or electrical apparatus adjacent to where live work is being performed (unless a coordinated live work task.) Section 8.11 added the words One or More members of the work team shall be designated as the safety Observer New section 8.19 Working on different potentials Section 10.4 added additional wording It is important, however, that G & B workers maintain air insulation between the uninsulated part of their body and the energised electrical apparatus subject to work. The air insulation shall never be compromised. Reduction of the air insulation distance eliminates one of the two (2) independent levels of insulation Paragraph to highlight mandatory wearing of gloves and sleeves when crane MAD is using table 1 Section 11 added a new general note regard EWP insulating ratings Section 12.1 added information regarding not laying equipment directly onto the ground Section 12.1.1 added not allowing to cut or modify sleeves Section 12.3 added additional information relating to rated equipment and covering requirements for GFN feeders Added wording to highlight working area of the glove is the only area to make intentional contact to the conductor or covers Also included the use of Insulated positioning tower and allowing for HV rated baskets without using a Liner Section 14 added definition for Ground Fault Neutralizer 	HV Live Work Committee
June 2021	8	<ul style="list-style-type: none"> Section 6.5 Clarification of the requirements for competency auditing/ re- assessment Section 6.7 Added information for PERU Operators when conductors are lifted in excess Of HV MAD's Section 10.4 Table 1 New Note 6 insulated extensions mounted to PERU, crane or task truck jibs Section 12.3 Added diagram showing working area of G&B Gloves Section 12.6 Added information for testing of Lugall handles Section 14 Definitions - Defined Vehicle Mounted Crane as Vehicle Loading Crane 	HV Live Work Committee
August 2021	9	<ul style="list-style-type: none"> Section 8.7 Isolation from Structures and other work parties/ sites Section 11 Elevating Work Platform Vehicles Section 12.3 Insulation/Cover up policy EWP's Section 12.6 Mobile Plant & Equipment Table 	

COPYRIGHT ©

This document is not copyrighted and may be copied and distributed as required.

Disclaimer The material contained in this publication has been developed for the use and guidance of the Distribution Businesses their contractors and subcontractors. No reader outside the Distribution Businesses should act on the basis of any matter contained in this publication without considering and, if necessary, taking appropriate professional advice upon his or her own particular circumstances. Each of the Distribution Businesses, contractors, Registered Training Organisations (RTO) and all other representatives of the VESI HV Live Work committee expressly disclaim all and any liability to any person in respect of anything and of the consequences of anything done or omitted to be done by any such person in reliance, whether whole or partial, upon the whole or part of the contents of this publication

Contents

1.	<u>INTRODUCTION</u>	5
2.	<u>PURPOSE</u>	5
3.	<u>SCOPE</u>	5
4.	<u>CONCEPTS</u>	6
5.	<u>HAZARD IDENTIFICATION, RISK ASSESSMENT AND CONTROL</u>	6
6.	<u>LIVE WORK PERSONNEL</u>	7
6.1	<u>Personnel selection</u>	7
6.2	<u>Medical Assessment</u>	7
6.2.1	<u>Initial medical assessment</u>	7
6.2.2	<u>Ongoing regular medical assessment</u>	7
6.3	<u>Training Standards / Experience</u>	8
6.3.1	<u>Mentor</u>	9
6.3.2	<u>Work Experience</u>	9
6.3.3	<u>Representative Range of tasks</u>	9
6.4	<u>Limited HV Live Work – Vegetation Control</u>	9
6.5	<u>Competency Auditing / Annual Re-Assessment</u>	10
6.6	<u>Re-entering the HV Live Work field</u>	10
6.7	<u>Plant Operators working in association with HV Live Work crews</u>	10
6.7	<u>Plant Operators Process Flow Chart</u>	12
7.	<u>WORK DOCUMENTATION</u>	12
7.1	<u>General</u>	12
7.2	<u>HV Live Work Approval</u>	13
8.	<u>SAFE WORK PRINCIPLES</u>	13
8.1	<u>Planning and criteria for deciding to carry out HV Live Work</u>	13
8.2	<u>Supervision / Leadership</u>	13
8.3	<u>Protective clothing / Apparel / Jewellery</u>	13
8.4	<u>Incident reporting</u>	14
8.5	<u>Protection systems</u>	14
8.5.1	<u>Ground Fault Neutralizer (GFN) / Rapid Earth Fault Current Limiter (REFCL)</u>	15
8.6	<u>Combining Stick methods with Glove & Barrier methods:</u>	15
8.7	<u>Isolation from Structures and other work parties / sites:</u>	16
8.8	<u>Work on Dual Circuit Structures</u>	16
8.9	<u>Combination HV Live Work and Access Authority Work</u>	17
8.10	<u>Insulator integrity provisions to conduct HV Live Work</u>	17
8.11	<u>Safety Observer</u>	18
8.12	<u>Elevated Conductor Temperature</u>	19
8.13	<u>Making and Breaking HV Bridges / Cutting Conductors:</u>	19
8.14	<u>Weather / Climate / Heat stress</u>	19
8.15	<u>Light Conditions</u>	20
8.16	<u>Night work</u>	20
8.17	<u>Mobile Plant Earthing Requirements</u>	20
8.18	<u>HV Live Work Tree Cutting and Limb Removal in and around High Voltage Conductors</u>	21
8.19	<u>Working on different potentials</u>	22

9.	<u>SINGLE PERSON ALOFT HV LIVE WORK TASKS</u>	22
10.	<u>MINIMUM APPROACH DISTANCE</u>	23
10.1	<u>General</u>	23
10.2	<u>Contact Area</u>	23
10.3	<u>Tool insulation distance</u>	23
10.4	<u>HV Live Work Minimum Approach Distances</u>	23
11.	<u>ELEVATING WORK PLATFORM VEHICLES (EWP'S)</u>	25
11.1	<u>Working on one phase from a EWP</u>	25
11.2	<u>Working on one phase from 2 EWP's</u>	25
11.3	<u>Working on separate phases utilising 2 EWP's</u>	25
12.	<u>EQUIPMENT</u>	26
12.1	<u>Care & Maintenance</u>	26
12.1.1	<u>Repair or modifying of rubber goods</u>	26
12.2	<u>New equipment</u>	26
12.3	<u>Insulation / Cover-up policy</u>	26
12.4	<u>EWP provisions and associated tools</u>	28
12.5	<u>Using Hydraulic Tools in Direct Contact with Live HV Apparatus</u>	28
12.6	<u>Electrical testing and labelling</u>	29
13.	<u>CONTINUOUS IMPROVEMENT</u>	29
14.	<u>DEFINITIONS</u>	30
15.	<u>REFERENCES</u>	32
	<u>APPENDIX A - HV LIVE WORK ACTIVITY - HAZARD / RISK ASSESSMENT & CONTROL MEASURES</u>	33
	<u>APPENDIX B - GUIDELINES FOR USING HYDRAULIC TOOLS IN DIRECT CONTACT WITH LIVE HV APPARATUS</u>	36
	<u>APPENDIX C - VESI HV LIVE WORK CRANE OPERATOR – INSTRUCTED PERSONS CHECKLIST</u>	39

1. Introduction

These VESI Minimum Rules for Carrying out High Voltage (HV) Live Work In Victoria have been formulated by the [VESI HV Live Work Committee](#) and have been circulated throughout the electricity supply industry in Victoria for the guidance of persons and organisations that conduct HV Live Work in Victoria.

The rules contained herein pertaining to HV Live Work are the minimum standard to be applied when conducting HV Live Work throughout Victoria. Organisations may enhance or supplement rules provided this does not result in reduced safety standards. The underlying aim of this document is to provide a consistent set of rules and guidelines, agreeable to all stakeholders, to be applied without alteration in order to eliminate confusion to HV Live Workers working across the State.

It is acknowledged throughout the electricity industry that safety is of the utmost importance, in regard to carrying out works, no other consideration is of equal importance.

2. Purpose

The purpose of the VESI Minimum Rules for Carrying out HV Live Work in Victoria is to:

- promote safety relevant to conducting HV Live Work
- provide an agreed standard common to all VESI Network Operators
- specify the minimum requirements to conduct HV Live Work on the VESI Electrical Networks

3. Scope

This document applies to employers, contractors and sub-contractors undertaking HV Live Work on the Distribution Networks in Victoria under the control of the Network Operator.

The rules contained in this document are to be read in conjunction with the following:

- Electrical Safety Rules for the VESI Distribution Networks (The Green Book)
- Organisational Live Work manuals
- Australian Standards AS5804.1, 5804.2, 5804.3
- Relevant Energy Networks Australia (ENA) guidelines
- Victorian Occupational Health and Safety Act 2004

Where rules in this document differ with an existing Australian Standard or ENA guideline or rule, the information contained in this document shall prevail for HV Live Work being conducted throughout Victoria. Where specific issues pertaining to relevant HV Live Work are not covered in this document the relevant Australian Standards AS5804.1, 5804.2, 5804.3 or relevant ENA guideline may provide guidance.

These rules cover HV Live Work distribution and sub-transmission work up to and including 66kV. Work defined as electrical operating is not considered HV Live Work and is not covered by this document.

This document does not constitute a HV Live Work manual nor does it set down HV Live Work practices and procedures.

These rules are not designed to substitute or override any presiding or relevant legislation, regulation or code of practice.

4. Concepts

The concept of the HV Live Stick technique is based on the principle that Lineworkers always maintain a minimum approach distance from any energised high voltage line or apparatus while performing work, using tools and equipment fitted to insulating sticks.

The concept of the HV Live Glove & Barrier technique is based on the principle that Lineworkers always maintain a minimum of two independent levels of insulation to prevent phase to earth and/or phase to phase contact

Where using insulated tools and equipment (hand sticks, cutters etc.) whilst performing Glove and Barrier work the insulated gloves and sleeves shall remain on at all times.

5. Hazard Identification, Risk Assessment and Control

An organisation's safe system of work shall include appropriate risk management processes to ensure hazards associated with work near electrical apparatus are identified, assessed and controlled.

The purpose of the risk assessment is to ensure that HV Live Work is performed such that the overall level of risk is as low as reasonably practicable. The risk assessment begins with the planning of the task as well as a field-based assessment using Job Safety Analysis (JSA) methodology by the crew prior to commencing the work. The risk assessment shall also include reference to a Safe Work Method Statement (SWMS).

The risk assessment should identify, assess and consider:

- Potential hazards
- The risks associated with those hazards
- The potential circumstances under which the risks could arise
- The consequences of the risks
- And the control measures that can be applied.

The risk assessment should consider a range of variables and include where applicable;

- What is to be accomplished
- How the work is to be carried out
- Worksite safety for the crew and general public
- Weather conditions
- Inspect the structure to be worked on for soundness
- Inspect the structures/conductors on either side of the structure to be worked on for soundness
- What are the potential second points of contact
- What are the drop zone considerations
- If displacing conductors what are the estimated conductor weights and loadings
- Who is conducting the task (consideration to appropriate authorisation)
- Are multiple EWP's going to be used
- Who will act as the designated safety observer(s)
- Is a HV Live Work Permit/Approval to carry out the work required
- Has auto-reclose been suppressed and/or HV Live Work sequence enabled

The JSA shall be formalised by signing the document by all workers on-site and be regularly reviewed for workplace compliance. The HV Live Work control measures (see Appendix A) shall be observed to ensure and maintain a safe work environment.

Distribution Network Asset owners / managers shall advise service providers / fieldworkers of any known hazards or risks that have the potential to impact on the safe outcome of the work e.g.

- conductor corrosion
- defective insulator types
- corroded or defective fittings
- structures in particular environments where hazards may be increased
- earth screened leads

Known banned tasks are the following;

- working on any compound filled HV underground cable termination box, or moving leads associated with these boxes.
- re-energising of porcelain surge diverters when connecting the lead with a hand stick. re-energising **is acceptable** when using a tool. e.g. cut-out and the surge diverter leads are already connected to the apparatus and the tool in energising the entire installation.

6. Live Work Personnel

6.1 Personnel selection

A formalised selection process should be used to select persons to attend HV Live Work training courses. Selected persons shall be qualified Lineworkers and have appropriate attributes such as:

- have had 2 years' experience as a Lineworker post completing the apprenticeship or Electrician to Lineworker program
- competent in a broad range of line work commensurate with the requirements of a Certificate III in ESI - Power Systems - Distribution Overhead and compatible with HV Live Work
- proven safety record
- able to give and receive clear and precise instructions
- personal attributes such as responsibility, concentration and the ability to work in a team
- physical capability to perform the role

6.2 Medical Assessment

6.2.1 Initial medical assessment

Prior to employment or training as a HV Live Worker, a medical assessment shall be carried out by a qualified medical practitioner to check that the Live Worker can physically meet the requirements to carry out the intended work and has no medical history or medical condition which could affect the safety of the Worker or the work team.

6.2.2 Ongoing regular medical assessment

Network operators or service providers should arrange routine medical assessments of their staff to ensure their continuing medical capability to perform their role safely.

6.3 Training Standards / Experience

HV Live Work training courses shall provide trainees with the theoretical knowledge, practical skills and competencies required for HV Live Work on energised high voltage conductors / apparatus.

The VESI prerequisite for undertaking any stream of HV Live Work training is a Certificate III in ESI - Power Systems - Distribution Overhead or Lineworker equivalent as determined by the Network operator.

HV Live Work training courses in either Stick or Glove & Barrier or a combination of both shall be based on the Australian National Transmission and Distribution Training Package.

UETTDRDP13 - Maintain energised HV distribution overhead electrical apparatus (stick)

UETTDRDP14 - Maintain energised HV distribution overhead electrical apparatus (glove)

HV Live Work training and assessment guidelines are also referenced in the Australian Standard AS5804.1 "High Voltage Live Working, Part 1: General.

HV Live Work training courses are competency based with supervised learning. Assessment time frames may vary due to a range of factors such as competency levels and course participant numbers. The anticipated minimum time frame of the formal training component for a nominal group of 4 trainees:

- 4 weeks for Glove & Barrier to 33kV
- 4 weeks for Stick to 66kV
- 5 weeks for Glove & Barrier and Stick to 33kV
- 6 weeks for Glove & Barrier to 33kV and Stick to 66kV

Training providers shall be Registered Training Organisations (RTO's) whose scope of registration accredits them to deliver the training.

In the best interests of the industry, distribution companies who own or manage the power line assets should and are encouraged to provide persons under training or working through work performance Workbooks, access to Network assets in an endeavour to contribute towards providing trainees with the best possible learning and experience outcomes. All Training or work experience (section 6.3.2) shall meet the relevant requirements of this document and have prior Network Operator approval for this activity.

Successfully carrying out HV Live Work is a combination of training that provides the underpinning knowledge, skill and competency, combined with experience across a broad range of situations.

After successful completion of the formal HV Live Work training, trainees must complete a work experience component (Workbook based) under the supervision of a mentor/s.

On completion of the work experience component a final capstone assessment will be conducted by an RTO (at least 70% practical) including analysis of evidence collected in the Workbook. The training course combined with the work experience component including the final capstone assessment shall be completed in not less than 3 months and not exceeding 12 months. If the capstone is not completed within the specified time frame, the participant shall cease live work until a competency reassessment is completed and a suitable training program is implemented. The relevant certificate is issued after successful completion of the capstone assessment.

Currency of competence is attributed for 12 months only (see section 6.5). Where continued currency is required, competency shall be re-assessed annually by an RTO.

6.3.1 Mentor

The Mentor is a person appointed in the workplace that is qualified with;

- a current and appropriate HV Live Work certification / qualification or equivalent, and
- a minimum of two years HV Live Work experience

The Mentor is not the assessor but is a person or persons who assist the trainee develop their on-job skills and knowledge.

6.3.2 Work Experience

After formal training has been successfully completed the work experience component (Workbook) shall be completed. The Workbook is where the trainee works with a mentor(s) to complete a representative range of tasks and work functions listed in the Workbook to further develop their HV Live Work skills.

After completion of the work experience component, analysis of the workbook evidence collected, a capstone assessment will be conducted by an RTO to determine final competency, and relevant certification / qualification will then occur.

6.3.3 Representative Range of tasks

Assessment criteria dictates for final assessment that a sufficient body of evidence be collected across a range of representative activities and work functions in order that a valid, reliable, fair and timely judgement about an individual's performance for attributing competence can be made.

Representative range of tasks are based on tasks undertaken during formal training and on typical HV Live Work activities a HV Live Worker may be expected to perform in the field. The representative range of tasks are outlined in the work performance component (Workbook), to collect evidence of tasks completed and tasks signed off by both the mentor(s) and the trainee.

6.4 Limited HV Live Work – Vegetation Control

Limited HV Live Work – vegetation control training provides the worker with the theoretical knowledge and practical skills required to perform limited HV Live Stick tasks up to 22kV for the purpose of vegetation control (Tree trimming) only. Limited HV Live Workers shall meet the relevant requirements of this document and have prior Network Operator approval for this activity.

As no specific national unit of competence exists for limited HV Live Work – vegetation control the training is based on relevant components of the national competency standard unit Maintain energised HV Distribution overhead electrical apparatus (Stick). The VESI Limited HV Live Work – vegetation control training details can be obtained from the VESI Skills and Training Guideline.

The course involves the limited use of HV Live Work equipment such as hand Sticks, fitting of conductor Insulating Barrier and insulated control ropes to facilitate the moving of HV conductors away from vegetation but does not allow actual work to be performed on conductors or the un-securing of conductors from a structure.

6.5 Competency Auditing / Annual Re-Assessment

To ensure ongoing safety, competence and adherence to work practices, HV Live Work Lineworkers shall be monitored in the field through formal competency auditing. These audits shall be documented, kept on file for analysis purposes and be conducted annually.

Audits shall assess demonstrated competencies against documented and approved HV Live Work techniques and tasks, work practices, rules, regulation, guidelines, equipment use storage and maintenance, and general site safety in order to provide a holistic review.

Assessments for Stick and/or Glove & Barrier work must include techniques for each task being performed.

The anticipated minimum time frame to undertake this competency assessment for up to a 4-person crew is:

- 1 day for Limited HV Live Work – vegetation control
- 2 days for HV Live Work - Glove & Barrier
- 2 days for HV Live Work - Stick
- 3 days for HV Live Work - Glove & Barrier and Stick

HV Live Work assessment tasks are to be performed in the field on live assets and should include a variety of tasks to allow participants to demonstrate their skills and competency utilising a range of techniques and equipment.

Where HV Live workers are found to be deficient in an area of work, remedial training specifically tailored towards those deficient areas shall be provided in line with the risks identified.

Currency of competency is for 12 months only. The assessment shall be undertaken by an RTO with the trainer/assessor remaining independent of the crew.

Where clarification is required, contact your Network operator representative.

6.6 Re-entering the HV Live Work field

Persons who have not undertaken HV Live Work and not successfully completed annual assessments and refresher programs for a period of up to 5 years shall undergo a training program and competency assessment by an RTO.

6.7 Plant Operators working in association with HV Live Work crews

Plant operators working with a HV Live Work crew shall have an understanding of HV Live Work techniques and be instructed in the HV Live Work task prior to the task commencing.

The following shall apply:

1. Pole Erection Recovery Unit (PERU) operators (that are not HV Live Work trained Lineworkers) who are used for HV Live Work tasks in the installation, replacement, removal and maintenance of poles and pole mounted electrical apparatus (e.g. switch replacement), shall undertake the VESI High Voltage Live Work - Pole Erection Recovery Unit Operator training as referenced in the VESI Skills & Training Guideline.
2. Vehicle Mounted Crane (VMC) operators (that are not HV Live Work trained Lineworkers) who are used for HV Live Work tasks in the installation, replacement, removal and maintenance of pole mounted electrical apparatus (e.g. switch replacement), shall undertake the VESI High Voltage Live Work - Vehicle Mounted Crane Operator training as referenced in the VESI Skills & Training Guideline.

3. Where mobile plant is used for 'live' conductor lifts, (even if the operator has completed the VMC/PERU VESI training) the work party/plant operator shall complete the VESI HV Live Work Crane Operator – Instructed Persons Checklist (Appendix C) and be instructed on the procedure and safe working distances required to safely undertake the task prior to the commencement of work. They shall be directed by a nominated member of the HV Live work team at all times.

PERU and VMC Operators shall undergo annual assessment or refresher training. The assessment/refresher training is to be performed in the field on live assets.

Any plant operator who has completed the VESI High Voltage Live Work - Pole Erection Recovery Unit Operator training module is not required to complete the VMC operator training.

The only time a PERU operator does not require VESI High Voltage Live Work - PERU Operator training is when a crane has lifted the HV conductors clear of the pole structure and the Green Book clearances are maintained at all times by the PERU and the attached load.

6.7 Plant Operators Process Flow Chart

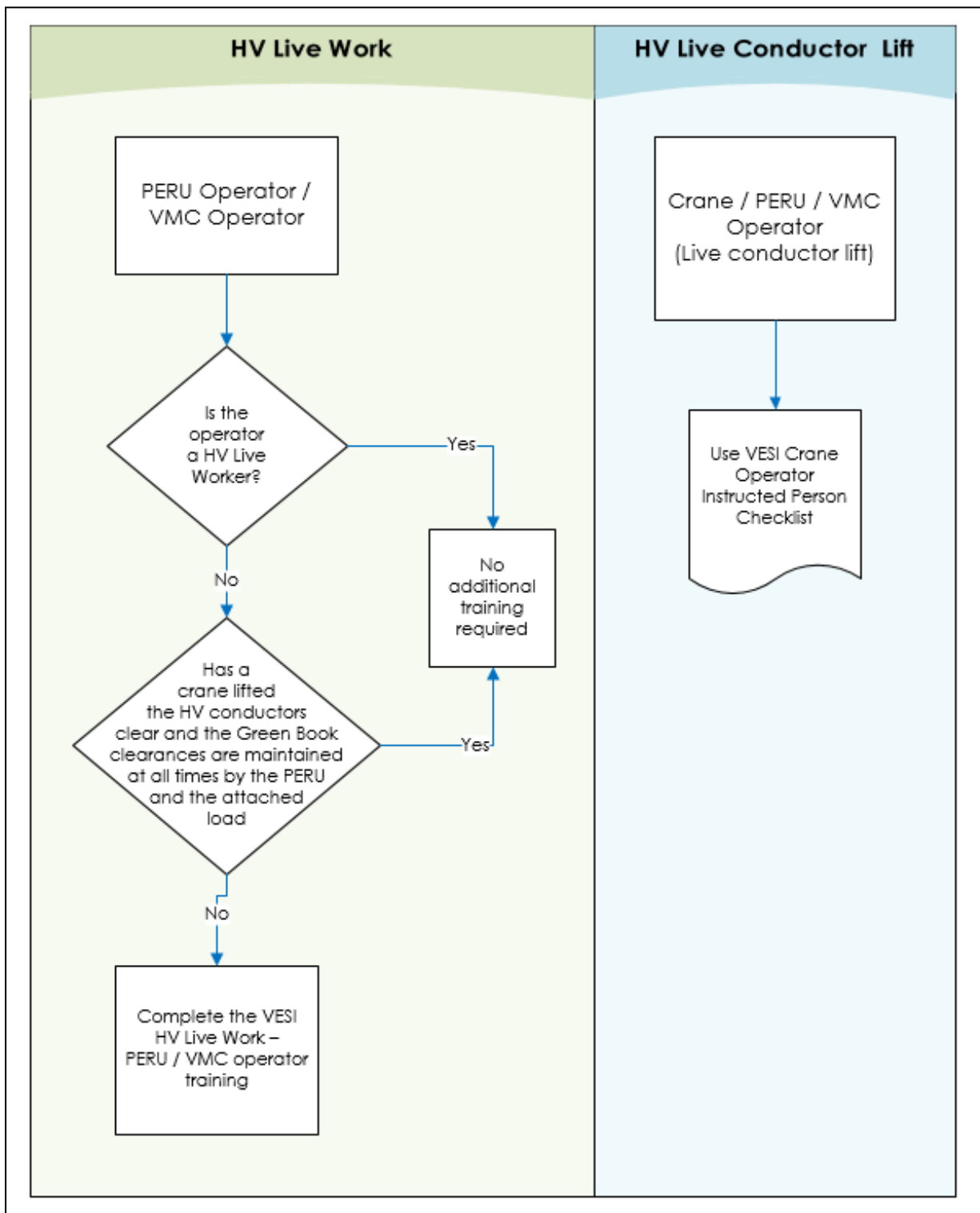

7. Work Documentation

7.1 General

To ensure its safe performance, the Live Work process shall be documented and effectively communicated to all staff involved. A Live Work manual shall be available for reference at the worksite.

7.2 HV Live Work Approval

A communication process is required to ensure access to live Network assets is approved. This includes;

- worksite locations and nature of the work are to be advised to Network Control Centre prior to commencing work
- auto-reclose facilities are identified and disabled
- the appropriate system protection settings are applied where applicable
- awareness when working on a GFN/REFCL Feeder
- Network Control Centre are to be advised when the work is completed

Work crews are responsible for directly communicating the status of their allotted task to Network Control Centre. Where more than one work team is working on the same circuit but at different locations, Network Control Centre shall ensure that all teams are clear of the line before the auto-reclose equipment is returned to normal.

8. Safe Work Principles

8.1 Planning and criteria for deciding to carry out HV Live Work

Whenever power line work is being planned, the ability to readily interrupt or alter the Network to enable work to be performed under shutdown conditions shall be considered as well as doing the work by Live Work Methods. The specific nature of the assets being worked upon and the proximity of other assets that may impose higher risks shall be considered. E.g. surge arresters on substation or cable head poles, earth screened leads. A risk assessment shall determine if HV Live Work on this type of structure can be carried out safely.

HV Live Work options shall be rejected on site if the work party believes that the work cannot be completed within appropriate Live Work and Safety guidelines.

8.2 Supervision / Leadership

Ongoing safety, competence and adherence to work practices is important. Supervision of HV Live Work crews should be an active and regular process able to effectively monitor and inspect HV Live Work field performance.

Supervision will allow meaningful task/method discussion to take place, effective communication of requirements and observation of non-conformances. To this end, supervisors/team Leaders of HV Live Work crews should be familiar with HV Live Work practices, rules and methodologies. All HV Live Work crew's / work sites should have a designated person in charge of activities.

8.3 Protective clothing / Apparel / Jewellery

Approved protective clothing covering the body from wrist to ankle including eye protection, safety hard hat and safety footwear shall be worn during HV Live Work.

No exposed personal jewellery shall be worn during HV Live Work. Other items such as mobile phones and pagers shall not be carried during HV Live Work as they may cause distractions and reduce concentration. Long hair shall be securely fixed and confined close to the head.

8.4 Incident reporting

Organisations shall have procedures in place for responding to incidents, that address all relevant considerations including;

- rescue of injured persons
- immediate first aid and medical needs
- emergency switching requirements
- investigation and reporting requirements
- implementation of appropriate remedial measures
- communication requirements

An incident is defined as, but not limited to the following;

- electric shock or other serious injury
- flashover / arc at, or close to the worksite
- complete or partial breakdown of any insulating tool or equipment
- electrical or mechanical failure of any HV Live Work equipment which did, or could have the potential to, cause an accident
- loss of conductor control

Any and all HV Live Work incidents or potential incidents shall be reported as per OH&S Incident Notification Regulations, current Electricity Safety (Network Assets) Regulations and the company prescribed reporting processes.

8.5 Protection systems

In line with relevant Australian Standards and or ENA guidelines, auto-reclose equipment controlling a circuit on which HV Live Work is to be performed shall be suppressed for the duration of the work unless specific and careful engineering and safety analysis indicates otherwise, and additional safeguards are considered to ensure that the work can be performed safely.

HV Live Work rules, practices, procedures, guidelines, insulated gear and equipment are all designed and intended to provide the primary safety protection for HV Live Work. All persons working on live high voltage lines must be aware of system protection capabilities and not under the assumption that protection trip devices are failsafe in the event of an incident. System protection devices are used to provide additional safety aspects however, depending on a range of factors, it should not be assumed that system protection devices will always operate to remove hazards, and may not operate in time frames to be of critical benefit.

Some modern feeder protection devices have mechanisms for readily varying their sensitivity, for the purpose of enabling them to detect any earth-fault-current initiated event at the earliest possible time. During any period when HV Live Work is being performed on a circuit protected by a device that has such a facility, the most sensitive setting shall be selected so as to provide the highest level of protection available.

8.5.1 Ground Fault Neutralizer (GFN) / Rapid Earth Fault Current Limiter (REFCL)

When HV live work is planned, the GFN will be placed into an operating mode (Live Work Mode) that does not allow the NER to be switched into service. The GFN will either immediately trip for a feeder fault or trip after performing a test to determine which feeder contains the fault and to check if the fault is sustained.

The GFN does not operate for phase to phase faults which will be cleared by conventional over current protection.

8.6 Combining Stick methods with Glove & Barrier methods:

As per Australian Standards AS 5804 1, 2 & 3, when HV Live Work is to be accomplished through a combination of Glove & Barrier and Stick methods the work shall be limited to situations where the safety margins are not decreased by introducing the live stick method into the contact area. Clear transition points and communication shall exist between Glove & Barrier / Stick techniques.

Lineworkers shall be certificated and have current competency in the HV Live Work method they are using. All Lineworkers carrying out HV Live Work Glove & Barrier method within the contact area shall wear insulating gloves and sleeves and these shall not be removed until they have moved outside the contact area.

Any Lineworker changing from Glove & Barrier method to Stick method shall move outside the contact area, remove their insulating gloves and sleeves, and re-enter the work area observing the HV Live Work minimum approach distance appropriate for the method and voltage concerned.

The following combinations of HV Live Work Glove & Barrier and Stick methods are not permitted:

- one Lineworker carrying out Stick work and one Lineworker carrying out Glove & Barrier work from the same EWP
- one Lineworker on a pole or structure carrying out Stick work and one Lineworker on an Insulating platform carrying out Glove & Barrier work

Supplementary to the above, given that some tasks require a combination of Stick and Glove & Barrier equipment, HV Live Work methods to accomplish a task (Stick method or Glove & Barrier method) shall be determined prior to commencement. Tasks should be started and completed using the same methodology.

8.7 Isolation from Structures and other work parties / sites:

Glove & Barrier work shall be performed from either:

1. An EWP approved for glove and barrier work (see section 11); or
2. From an approved insulated rated and tested platform.

The Lineworkers belt / harness shall remain at the same potential as the Lineworker and prevented from contacting any component at a different potential to the Lineworker.

No work shall be undertaken on structures, spans or electrical apparatus adjacent to where live work is being performed (unless a coordinated live work task.)

As the gap between an over/ under crossing can be compromised, no HV Live Work shall be carried out on the common pole or first adjacent poles of an over/under crossing where construction / maintenance work is being carried out concurrently.

E.g.

HV Live Work not permitted on the common pole or first adjacent poles of an over/under crossing

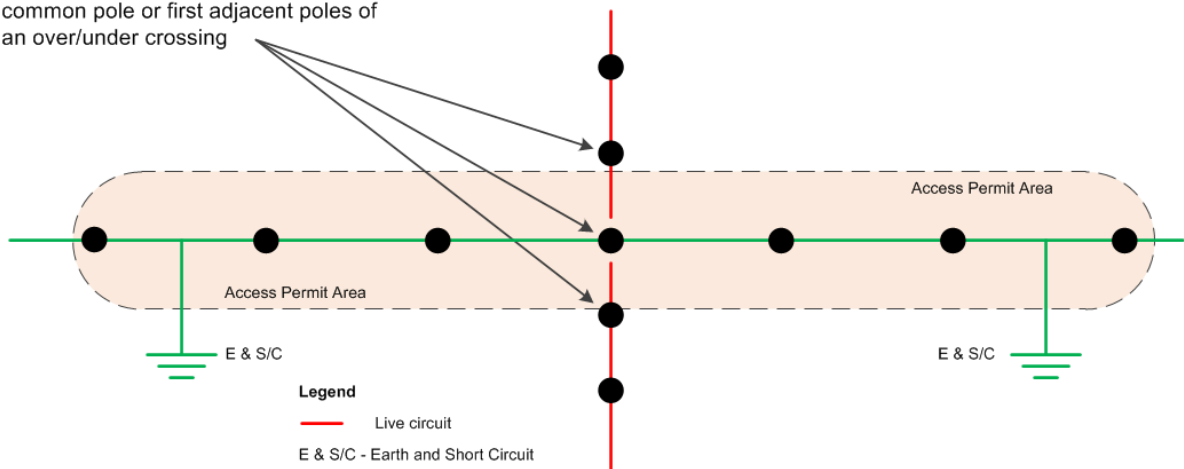

8.8 Work on Dual Circuit Structures

When undertaking work on dual circuit structures, steps shall be taken to identify the circuit to be worked on. These steps shall be discussed during the on-Site Risk Assessment and can include circuit labels, HV switch No's, feeder diagrams, barriers etc.

Where the circuit not being worked on is of a different voltage, e.g. 66kV when performing 22kV Glove & Barrier work, this shall be specifically recorded on the Site Risk Assessment and clear and specific instruction given to the safety observer to ensure the HV work party maintain clearances and the correct circuit is worked on at all times.

8.9 Combination HV Live Work and Access Authority Work

HV Live Work and work under an access authority shall only be conducted on the same structure providing that:

- the two work methods are not undertaken simultaneously
- clear transition points shall exist between the HV Live Work and access authority work. This transition process shall be communicated to all of the work party
- HV Live Work personnel who are required to work aloft and/or other persons likely to infringe the contact area via a conductive medium e.g. PERU operator or person pushing the pole into the pole hole who have signed on to an access authority shall sign off the access authority before ascending to perform HV Live Work or operating the PERU to stand the pole. For the access authority to remain current (open), the recipient in charge must remain signed on to the permit and must remain on the ground
- all conductors that have been moved or repositioned are secured using the appropriate techniques and equipment
- HV Live Work minimum approach distances are established and maintained using HV Live Work techniques and or equipment between the live circuit and access authority area

Where HV Live Work is undertaken on a circuit above or below a circuit under access authority and not on the same structure as the Live Work, isolation shall be established on that circuit between the work parties performing the access authority work and the HV Live Work.

8.10 Insulator integrity provisions to conduct HV Live Work

All insulators in the immediate work zone should be visually inspected prior to work to ascertain the existence and extent of any damage. This damage should be carefully assessed to ensure that the insulator is safe to approach and work on.

Any insulator or insulator string exhibiting physical damage or signs of electrical stress, such as elevated noise levels or surface discharging shall be approached with care and appropriate safe working techniques adopted to minimise the risk of flashover and consequent injury to workers.

Where reduced insulating properties are known or suspected, work electrical hazards such as step and touch potentials may exist at the structure. Appropriate safe work practices should be adopted such as:

- performing a safe to approach test before climbing
- undertaking the work from an EWP
- covering the insulation with one or more mats
- undertaking the work using HV Live Work Sticks instead of the Glove & Barrier method
- performing the work under access permit conditions

8.11 Safety Observer

During all HV Live Work, one or more members of the work team shall be appointed as the designated Safety Observer. The designated Safety Observer's role is to alert the work team to any potentially unsafe actions or lack of compliance with approved work practices, procedures or documentation.

The designated Safety Observer shall:

- be a live HV worker; OR, have successfully completed the formal training component of the relevant HV Live Work training course
- be identified on the risk assessment form
- be visually identifiable as the safety observer
- be positioned at a suitable location to observe the work being performed
- be in position before work starts
- be aware of how the task will progress and any changes made during the task
- have the authority to suspend the work at any time
- maintain effective and immediate communication with the work team at all times
- not perform any other task whilst HV Live Work is in progress
- suspend all work in the event of having to leave the site or significantly change position until he/she has returned/reached new location or has been replaced

HV Live Work is a team effort and as such all team members are safety observers for each other. The designated safety observer is appointed by the team.

The "Designated Safety Observer" shall observe at all times whilst the HV Live Work task is in progress. The designated safety observer should be stationed at ground level unless another position provides greater viewing benefit to provide a holistic and broad view of the work.

If during a task the designated safety observer's view is impaired by some obstruction, he/she must communicate this to the crew aloft carrying out the task and may for short periods transfer the role to a Lineworker of the crew working aloft. When this occurs, it shall be conscientiously communicated so that all members of the work party are aware at all times who is performing the role of the Safety Observer.

The designated Safety Observer's role may be rotated between members of the work team (e.g. to reduce fatigue). When this occurs, it shall be documented on the risk assessment.

Where work is being performed utilising 2 EWP's on the same phase simultaneously, one Safety Observer may be considered after a documented job safety assessment has been completed

Where work is being performed utilising 2 EWP's on separate phases simultaneously, two (2) Safety Observers shall be utilised

8.12 Elevated Conductor Temperature

Electrical apparatus operating with current will have a temperature above ambient. The temperature will depend on the current, the solar radiation and the prevailing wind.

Elevated conductor temperatures are a risk management issue for the Live Work process and are of particular significance for Glove & Barrier work as elevated temperatures may damage insulation integrity.

All HV Live Workers should be aware of this issue and take appropriate steps to ensure worksite safety.

8.13 Making and Breaking HV Bridges / Cutting Conductors:

HV Live Work methods involve working with energised circuits generally carrying electrical load / current. However, HV Live Work methods are generally not designed to switch loads. Circuits with load shall not be connected or disconnected unless a suitably rated load connection and disconnection device is used.

Current / load should be assessed or measured. Where the load is to be measured a suitable measuring device should be used prior to making or breaking bridges or similarly prior to cutting conductors in association with fitting Mid Span Isolators (MSI's).

Prior to the making / breaking bridges or the cutting of conductors the work party shall stop and assess that the controls put in place are adequate. The work party and Safety Observer shall confirm the following where applicable:

- the correct feeder / circuit is being worked on
- the correct phase is connected
- a suitably rated Hopper is used, secured and tightened
- a suitably rated load connection and disconnection device is used

8.14 Weather / Climate / Heat stress

HV Live Work shall not be performed in unsuitable wet, windy and stormy weather conditions. Prior to commencing any HV Live Work task, weather conditions for the day shall be considered. Weather conditions for the day may be unsuitable because of:

- electrical storm
- rain, fog, snow, mist, or sleet
- excessive wind velocity
- excessive heat
- excessive humidity

Where work is being conducted and heat stress may be a factor organisations carrying out the work shall have in place an inclement weather policy designed to minimise exposure to heat stress and hot environments as well as providing necessary work-rest cycles and water to minimise heat stress.

If HV Live Work is in progress and the weather conditions deteriorate to a point where it becomes unsafe to continue, the HV Live Work shall be suspended. Where temperatures rise above a comfortable level the risk of heat stress and fatigue increases and as such Glove & Barrier work should be suspended.

8.15 Light Conditions

Adequate light must be available to perform HV Live Work tasks to ensure:

- workers are able to see what they are doing
- the safety observer is able to see what the workers aloft are doing
- all other items within the work area that pose a risk are visible

8.16 Night work

All works conducted at night or in adverse light conditions shall be risk assessed and documented.

Adequate lighting shall be provided to eliminate distracting shadows from the worksite. Worksite lighting should be passive and set up that it doesn't blind the workers.

Equipment such as portable lighting towers needs to be placed in safe positions within the worksite.

Other areas identified as risks for HV Live Work at night may be considered for management of risk such as:

- the point at which dew forms "dew point" needs to be considered
- weather conditions may not be as predictable due to the lack of day light
- HV Live Work is such that it requires a high level of concentration and all members of the crew need to be alert
- at night the effect of flashing lights may be a distraction and the effects of shadows should be considered
- with the lighting equipment there may be added noise due to the requirement for generators which could impair the effectiveness of communication between those aloft and the safety observer or ground staff

8.17 Mobile Plant Earthing Requirements

Mobile plant such as EWP's, Cranes, PERU's or Task Trucks used in conjunction with HV Live Work shall be electrically connected to earth via a conductor from the chassis to a permanent earth or temporary driven earth electrode. The lowering of an earth chain is not an adequate means of earthing when undertaking HV Live Work.

Mobile plant should be parked at least 2 metres apart to reduce different potential issues. The separated mobile plant shall be separately earthed.

Where the mobile plant items are parked closer together than 2 metres they shall be bonded together to a common earth system / electrode.

Where earthing of plant and equipment is not practicable (e.g. concrete/bitumen area) then the plant shall be barricaded to 2 metres to prevent access to manage the step & touch potential hazard.

Conductive poles being lifted in proximity with live HV conductors shall be bonded to the lifting plant prior to lifting or unless safety analysis indicates otherwise, and a documented process is available to ensure that the work can be performed safely.

No contact shall be made with earthing (bonding) conductor or EWP(s) or PERU(s) or any other vehicle engaged in HV Live Work while the work crew are engaged in Live Work within the contact area or is in any way in contact with live conductors.

All personnel and members of the public shall be kept clear of the worksite where reasonably practicable while Live Work is in progress. Mobile plant items that have control levers or remote controls that may be operated whilst standing on the ground shall not be used unless the operator is:

- standing on a conductive mat that is electrically bonded to the vehicle; or
- positioned on the vehicle; or
- at least 6 metres from the vehicle and/or earth electrode

8.18 HV Live Work Tree Cutting and Limb Removal in and around High Voltage Conductors

Where tree limbs and foliage within 300mm of, or anywhere above Live HV conductors are to be removed, it is considered to be a HV Live Work task. Persons engaged in HV Live Work tree cutting tasks shall have either undertaken training in a National Live Work Competency Standard Unit or VESI Limited HV Live Work - Vegetation Control and be assessed as having the appropriate skills and knowledge for the task.

To ensure system security in the event of loss of control of a limb section, foliage / limbs must be cut in small sections of a size so as to not be able to bridge across conductors or between conductors and the supporting structure. Using HV Live Work pruners or approved hydraulic saw, trim foliage / cut limb in short sections (not more than 300mm in length).

Public safety must be carefully considered and managed in terms of both falling debris and possible step and touch potential at the tree base.

- on-site discussion / job planning and risk assessment must indicate that foliage / limbs (while being cut), can be managed and removed in a way so as to not come into direct contact with high voltage conductors
- controlled roping techniques of limbs may be required. The integrity / soundness of trees to be worked on and limbs to be removed must be determined
- give due consideration to covering low voltage and any other subsidiary circuits in the immediate work area
- where foliage / limbs above high voltage conductors are to be trimmed / cut, two persons aloft are required
- give due consideration to wind effects on both conductor sway and tree limb movements
- when aloft, EWP basket must be positioned so as to maintain all appropriate clearances from live components and falling foliage / limbs
- where foliage / limbs to be trimmed are making contact or brush contact with a conductor, or could potentially make contact with a conductor during the trimming and removal process, one of or a combination of the following actions should be undertaken prior to trimming:
 - a. fit a cover(s) to the conductor(s)
 - b. restrain and control the foliage / limb with a HV Live Work Stick
 - c. restrain and move the conductor away using a HV Live Work Stick
 - d. restrain and control the foliage / limb using an insulated HV Live Work control rope anchored at ground level

- e. restrain and move the conductor(s) away using an insulated HV Live Work control rope anchored at ground level
- ensure a Safety Observer is in position prior to ascending

In the case of single person aloft, only (a), (d) and (e) above are applicable

Where single person aloft techniques are used, the HV Live Work tasks involved are limited to fitting of Insulating Barriers as required and fitting of control ropes if required and the trimming tasks are limited to foliage / limbs below or adjacent to but not above HV conductors.

During all HV Live Work, one member of the work team shall be appointed as the designated Safety Observer.

In the case of single person aloft the EWP basket must be positioned below HV conductors.

8.19 Working on different potentials

Crews shall ensure that when two people in the same EWP basket are working, they are not simultaneously working on the hot end of an insulator while the other person is working on the cold end, or one person holding a conductor while the other person is working on the pole. E.g. replacing a centre phase assembly.

9. Single Person aloft HV Live Work Tasks

Single person aloft tasks are to be read in conjunction with the HV Live Work – hazard / risk assessment and control measures Appendix A - Work on high voltage electrical apparatus (HV Live Work) including single person aloft tasks.

A single person aloft cannot perform any task that involves physically/personally moving or displacing a conductor or installation or removal of a hopper.

During all HV Live Work, one member of the work team shall be appointed as the designated Safety Observer.

All HV Live Work Lineworkers undertaking single person aloft tasks shall be suitably instructed for this type of work.

Allowable tasks by a single person aloft are:

- install / remove fault detection and recording equipment
- install / remove insulating barriers
- install / remove vibration protection
- install / remove bird covers – (Limited to where working position does not involve working over a conductor, only permitted on intermediate or slight angle poles, NOT permitted on substation or switch or fused structures)
- install / remove “D” loops (off load only / no circuit connection)
- install / remove spreader ropes
- Re-tie over the top of existing tie only (pre-form ties not allowed)
- TVI rectification (limited to lubrication)
- tighten hardware (cross arms and insulators)
- HV cross arm inspection

10. Minimum Approach Distance

10.1 General

The Minimum Approach Distance (MAD) is the minimum air gap measured between any part of the Live Worker and live electrical apparatus. Live Workers are not to bring any part of their body or anything they wear or any conductive apparatus they are carrying, closer to live equipment apparatus other than the MAD set for that voltage.

It is essential that the MAD shall always be maintained. Where this distance is visually estimated, any potential error in the estimation shall always be to increase the distance.

10.2 Contact Area

Glove & Barrier Lineworkers make insulated contact with live apparatus wearing insulated gloves and sleeves. These workers shall observe a "Contact Area" which is defined as an approach distance of one metre to the nearest energised high voltage line or component up to and including 22kV and shall ensure they wear appropriate gloves and sleeves at all times while in this contact area.

10.3 Tool insulation distance

The tool insulation distance is the minimum effective length of exposed insulating material (Stick), which is subjected to the voltage being contacted. This distance shall be measured between the metal end fitting at the conductor end of the insulating material and the hand mark where the Stick is gripped by hand.

10.4 HV Live Work Minimum Approach Distances

The following table (Table 1) outlines the distribution and sub-transmission voltages up to & including 66kV and the minimum approach distances required from the person, plant, equipment or conductors to live HV overhead conductors / equipment covering both Glove & Barrier and HV Stick work.

These distances shall not be reduced at any time and if it is considered at any time prior to or during a task that the relevant distances cannot be maintained the task shall not be performed.

Glove & Barrier Lineworkers shall maintain an air gap of 100mm between the uninsulated part of their body and any energised equipment at all times.

It is important, however, that G & B workers maintain air insulation between the uninsulated part of their body and the energised electrical apparatus subject to work. **The air insulation distance shall never be compromised.** Reduction of the air insulation distance eliminates one of the two (2) independent levels of insulation.

Where table 1 is used for hanging apparatus on a pole, for example a gas switch, the aerial crew attaching switch to pole shall wear gloves and sleeves until crane is outside MAD.

Table 1 - HV Live Work Minimum Approach Distances

Worker / Plant / Equipment / Conductor	Stick Technique		Glove & Barrier Technique	
	Voltage ¹	Distance	Voltage ¹	Distance
HV Live Work Lineworker	22kV	400mm ²	22kV	Contact - with gloves and sleeves 100mm - between uninsulated body & live apparatus
	66kV	600mm		
EWP HV insulated section ³	22kV	250mm	22kV	250mm from uncovered conductors
	66kV	600mm		Contact – with Insulating Barriers
EWP and Mobile Plant Non-insulated section to uncovered conductors	22kV	700mm	22kV	700mm
	66kV	900mm		
EWP and Mobile Plant non-insulated section to Covered conductors	22kV	400mm	22kV	400mm
	66kV	600mm		
Mobile Plant ⁴ Load (e.g. Pole Erection) (The load and conductors shall be covered)	22kV	400mm	22kV	400mm
	66kV	600mm		
HV Insulated Lifting Equipment ⁶	22kV	Contact	22kV	Contact
	66kV	Contact		
Non-Insulated Lifting Equipment to covered conductor	22kV	400mm	22kV	400mm
	66kV	600mm		
Non-Insulated Lifting Equipment to uncovered conductor	22kV	700mm	22kV	700mm
	66kV	900mm		
HV Conductor Spacing when temporarily relocating conductors	22kV	450mm	22kV	450mm
	66kV	900mm		
HV Stick insulation distance ⁵	22kV	400mm	22kV	400mm
	66kV	600mm		

Notes

¹ Less than or equal to the listed voltage

² The use of Insulating Barriers should be considered

³ When using an insulating EWP or insulating platform between circuits a minimum of 250mm clearance shall be maintained between the basket of the EWP and the lower circuit. This could include HV & Low Voltage conductors, aerial earths, catenary cable, pay TV and any other conductive mediums.

Where insulating barriers rated for the higher voltage are fitted to the lower circuit, contact can be made with the Insulating Barrier.

⁴ Mobile Plant operators shall be directed by a nominated member of the HV Live work team at all times. Double insulation on conductors maybe used, where pole is lowered down between conductors.

⁵ The Stick insulation distance must be increased where the task requires the hot end of the Stick/ tool to go past the live conductor resulting in a reduction of the MAD. E.g. Tying in a 22kV conductor the Stick end may go 150mm past the conductor position and as such the Tool Insulation Distance would be 400mm + 150mm = 550mm.

⁶ Excludes insulated extensions mounted to PERU, crane or task truck jibs which shall meet the requirements of the EWP and Mobile Plant Non-insulated section to uncovered conductors or EWP and Mobile Plant non-insulated section to covered conductors.

11. Elevating Work Platform Vehicles (EWP's)

Fibreglass booms are fitted to Elevating Work Platform Vehicles (EWPs) as an insulation medium where EWPs are intended for work in the vicinity of live electrical apparatus.

EWP's used for glove & barrier work shall have upper boom insulation, be fitted with an insulating basket liner or HV insulated basket and tested in accordance with AS/NZS 1418.10.

The boom insulation section, the HV insulated basket and/or insulating basket liner shall be rated and tested for the system voltage.

The current Australian Standard 1418 part 10 also calls for a lower boom or chassis insulator. This may either be a turret insulator or a bottom boom insulator. This insulator is generally a 33kV insulator.

11.1 Working on one phase from a EWP

Where HV Live Work is being performed utilising one EWP, work shall be restricted to one phase at a time.

11.2 Working on one phase from 2 EWP's

When work is being performed using 2 EWP's on the same phase, no minimum separation is required between the baskets, but care is required to ensure that the work of one person does not compromise the safety of another.

Where these EWP's are operated with one Live Worker in each basket, tasks such as; moving or displacing a conductor or installation or removal of a hopper may be undertaken provided they are working as a crew together and in a co-ordinated manner.

Where work is being performed utilising 2 EWP's on the same phase simultaneously, one Safety Observer may be considered after a documented job safety assessment has been completed.

11.3 Working on separate phases utilising 2 EWP's

Where 2 EWP's are utilised for HV Live Work, two phases may be worked on simultaneously provided that a minimum separation of two (2) metres (i.e. air gap) between the baskets and booms of the EWP's is maintained at all times.

No tools and/or equipment shall be passed between the EWP baskets while physically working on conductors. Care shall be taken to ensure that the work of one person does not compromise the safety of another (i.e. encroach on the clearance space of another person).

Where work is being performed utilising 2 EWP's on separate phases simultaneously, two (2) Safety Observers shall be utilised.

12. Equipment

12.1 Care & Maintenance

All Live Work equipment shall be inspected and maintained at regular intervals in accordance with manufacturer's instructions, Australian standards, VESI and Network operator requirements

HV Live Work equipment, insulating tools and ropes shall not be:

- Laid directly onto the ground. (An equipment rack or ground sheet shall be used)
- Stored near greases and oil-based substances.

Live Work equipment management system shall be in place to ensure equipment is inspected, maintained and tested to set standards and at appropriate intervals. Records shall be kept for the working life of the equipment.

12.1.1 Repair or modifying of rubber goods

- Repair of rubber goods is not acceptable on the Victorian Networks
- Cutting or modifying sleeves not allowed

12.2 New equipment

Appropriate HV Live Work tools and equipment are essential for safe HV Live Work. Any and all equipment used, created, manufactured for the purpose of HV Live Work shall be designed, tested and approved specifically for HV Live Work, capable of being safely used on energised high voltage conductors / apparatus.

All equipment shall be rated and certified for use by the manufacturer and shall meet the relevant standards as listed in the Australian Standards AS5804.1, 5804.2, 5804.3. Other rules in regard to HV Live Work tools, equipment, care and maintenance shall be as specified by other relevant ENA guidelines for HV Live Work.

12.3 Insulation / Cover-up policy

Insulating material is an integral part of any HV Live Work. Lineworkers carrying out Glove & Barrier work shall wear appropriately rated and tested insulating gloves and sleeves and:

- always work from an approved EWP, insulated positioning tower or insulating platform only
- ensure the EWP is fitted with an insulating basket liner or HV insulated basket
- cables and HV Live Work equipment shall always be positively controlled
- ensure all sources of potential difference capable of being reached, including within the "Drop Zone" are covered

Where a conductor is to be rested/placed on any uninsulated part of a structure one of the following techniques shall be applied:

- Use of an appropriately rated Temporary Conductor Support; or
- At least two forms/levels of insulation rated to the voltage being worked on

For conductors on **REFCL / GFN**

- i. A class 3 hard cover and at least two rated insulating mats
- ii. A class 3 rubber hose and at least one rated insulating mat

For insulated hoppers

- i. Flexible - minimum 25kV rated and at least one rated insulating mat
- ii. Rigid - hopper shall be used in combination with a rated insulating mat

The following type of equipment shall only be used on REFCL systems with extension insulators installed:

- Auxiliary Arm
- Temporary Conductor support
- Extension Arm
- Pole mounted conductor support arm

Before Glove & Barrier work is performed, gloves and sleeves shall be visually inspected for insulation integrity, and the gloves shall be field air tested. All other equipment shall also be cleaned and inspected prior to use. Insulating gloves and sleeves shall not be worn inside-out and shall be worn with approved leather protector gloves. All intentional contact should only be made with the working area (refer to figure below) of the gloves protected by the leather outer gloves.



Figure: Working area of glove

A Glove & Barrier crew shall work on one phase at a time only. Barriers and cover-up equipment is intended and designed only to protect Lineworkers from accidental contact with components other than the component being worked on.

When undertaking Glove & Barrier work, gloves and sleeves shall be worn at all times inside the Contact Area and not removed until outside the Contact Area.

Insulating barriers should not be left on energised components overnight or for prolonged periods. Where this has occurred, the integrity of the insulation cannot be depended upon, and the barriers shall be visually inspected and cleaned if necessary before re-use. Any doubt as to the integrity of the insulation value will require the barriers to be electrically re-tested.

Contact shall not be made with live components or barriers with any uncovered / unprotected part of the body. Contact may only be made with insulating gloves, Sticks and appropriate HV Live Work tools.

Insulating barriers should be progressively fitted starting with the nearest live apparatus / source of potential difference and should be removed in the reverse order. Where possible, covers should be fitted from below.

12.4 EWP provisions and associated tools

When not in use the EWP basket liner shall be covered to keep the inside clean and free from moisture and debris. Before using an EWP for HV Live Work the insulated section of the boom shall be inspected, cleaned and dried. Items that might adversely affect the insulation value such as rope, cable, or washing hoses, shall be removed. Hydraulic hoses shall be non-conductive and be inspected and cleaned.

Where power tools are required in close proximity to live components, approved hydraulic tools are recommended. Where hydraulic tools are not available and electric power tools are the only type available, electric power tool leads shall not be brought into close proximity to live conductors. Electric tools and leads shall maintain at least one metre clearance from live components and leads shall be controlled and physically restrained.

12.5 Using Hydraulic Tools in Direct Contact with Live HV Apparatus

Appendix B attached hereto is the guideline which outlines the minimum requirements for the use of hydraulic tools when they are used in direct contact with Live HV apparatus and connected to the hydraulic tool outlets of an EWP whilst undertaking HV Live Work (up to and including 33kV).

12.6 Electrical testing and labelling

All HV Live Work insulating equipment shall be electrically tested to prove insulation integrity on a regular basis or where the integrity of such insulation is suspect. In line with Australian Standards AS5804.1, 5804.2, 5804.3 insulating gloves, sleeves and flexible barriers designed for HV Live Work are available in four classes which are listed below.

Class	Rated Voltage (AC Proof Test)	Maximum Use Voltage
1	10 kV	7.5 kV
2	20 kV	17 kV
3	30 kV	26.5 kV
4	40 kV	36 kV

The recommended maximum testing intervals are defined in the appropriate Australian Standards AS5804.1, 5804.2, 5804.3 and are indicated in the table below.

Personal Equipment	Test Intervals
Insulating gloves and sleeves	6 months
Insulating blankets	6 months
Rubber insulating line hoses, connectors and Insulating Barrier	6 months
Insulated jumpers	6 months
Rigid line Insulating Barrier	12 months
Conductor support equipment, insulating platforms, temporary dropout tools, insulating Sticks including hand Sticks. Where Lugall's are used for Stick Work, insulating handles must be tested.	12 months

The recommended testing intervals for EWP's are defined in Australian Standard AS/NZS 1418.10

Mobile Plant Equipment	Test Intervals
Insulated EWP's	6 months
Insulated EWP basket liner	6 months
Insulated hoses	6 months

Note: High equipment usage may necessitate more frequent testing intervals.

All insulating equipment shall carry an in-test identification mark (Sticker or stamp) to show the date of the next routine test and be identified on a current test register. Equipment not identified as being in-test shall not be used to carry out HV Live Work.

13. Continuous Improvement

Suggestions for improvement to this document can be submitted via the [Contact Us](#) on the VESI HV Live Work webpage. Suggestions will be considered by the committee for incorporation. Any changes to this document can only be made by consensus agreement between the Network Operators.

14. Definitions

Approved	Having appropriate organizations endorsement in writing for a specific function.
Contact Area	The area within one metre of the nearest energised high voltage line or component whilst carrying out Glove & Barrier work
Drop Zone	The area below the immediate work position where a conductor or live equipment connected to live apparatus could become uncontrolled (Dropped) during the work process. All sources of potential difference in the drop zone area capable of being reached, or which are, or could be at a different potential to the component being worked on shall be covered with approved insulating barriers
Ground Fault Neutralizer/ Rapid Earth Fault Current Limiter	The Ground Fault Neutralizer (GFN) rapidly detects phase to earth faults and can extinguish electrical arcs. This in turn can help prevent bushfires and can reduce the health and safety risk associated with single earth faults. The GFN is also referred to as a Rapid Earth Fault Current Limiter (REFCL) because it rapidly reduces earth fault current from thousands of Amperes to close to zero. During a fault, the phase to earth voltage on the unfaulted phases can be subject to an increased voltage (up to 24kV).
Insulating Barrier (cover up equipment)	A barrier of insulating material specifically designed, approved and tested to the rated voltage for use as a line cover, insulator cover, cut-out cover, cross arm cover, dead-end cover or as a cover for similar Live Work equipment. Insulating barriers may be rigid or flexible and are intended to provide electrical protection for Live Workers, plant and attached loads should accidental brush contact with live components occur
Insulating Gloves and Sleeves	Insulating gloves and sleeves specifically designed, approved and tested to a rated voltage and worn with approved leather protective gloves
Insulating Platform	A platform of insulating material specifically designed, approved and tested for use with the Live Work Glove & Barrier method
HV Live Work	All work involving access to high voltage components of electrical apparatus capable of being energised, without implementing the established practice of isolating, proving de-energised, and earthing at the worksite
HV Live Work Glove & Barrier Method	A method of performing HV Live Work where the Lineworker is fully insulated from earth and other phases, using approved insulating gloves and sleeves, insulating platform and/or insulated elevating work platform and insulating barriers

HV Live Work Stick	A solid or filled Stick of insulating material specially designed, approved and tested for use in physically bridging the distance between the Lineworker and energised components, between the energised components and earth, between adjacent phases, or to enable physical loads to be taken or tools to be applied
HV Live Work Stick Method	A method of performing HV Live Work using tools and equipment mounted on HV insulated Sticks with the Lineworker maintaining the minimum approach distance from energised components
Limited HV Live Work	Limited aspects of HV Live Work (Stick work up to 22kV) for the purpose of vegetation control (Tree trimming etc.).
Live Work equipment	All Live Work tools, rope, gloves and insulating equipment used for HV Live Work
Mentor	<p>The Mentor is a person appointed in the workplace who is qualified with;</p> <ul style="list-style-type: none"> • a current and appropriate HV Live Work certification / qualification or equivalent, and • a minimum of two years' experience. <p>The Mentor is not the assessor, but is a person or persons who assists the trainee develop their on-job skills and knowledge</p>
Mobile Plant	Means cranes, elevating work platforms, tip trucks or similar plant, any equipment fitted with a lifting jib or boom and any device capable of raising or lowering a load. Mobile plant can only be considered as a vehicle when in the normal travelling mode and not in the working mode when determining minimum approach distances
Other Cable Systems	Telecommunications cables, Pay TV cable, Control cables, Aerial earthed cables, Electrolysis drainage cables
Procedure	The documentation of a systematic series of actions (or activities) directed to achieve a desired result
Registered Training Organisation (RTO)	A registered training organisation is a vocational education and training organisation registered by registering body in accordance with the Australian Quality Training Framework (AQTF) whose scope of registration accredits them to deliver the training
Tested	Tested in accordance with the relevant standard
Vehicle Mounted Crane (VMC)	A VMC is described as a Vehicle Loading Crane (VLC) which is a crane mounted on a vehicle for the purpose of loading and unloading items on or off the vehicle.

15. References

Australian Standards AS5804.1

Australian Standards AS5804.2

Australian Standards AS5804.3

Appendix A - HV Live Work Activity - Hazard / Risk Assessment & Control Measures

This table identifies HV Live Work activities, associated risk factors and industry control measures to be observed to ensure and maintain a work environment safe and free from risk of injury.

Task / Activity	Hazards / Consequences	Control Measures
<p>Work in the vicinity of live high voltage electrical apparatus, low voltage electrical apparatus, and other cable systems.</p>	<ul style="list-style-type: none"> • Death <ul style="list-style-type: none"> ○ Electrocution ○ Falls ○ Crushes • Serious injury • Electric shock • High voltage burns • Low voltage burns • Flashover • Induction • Damage to plant, equipment and assets • Impact from falling objects (struck) • Energisation via back feed • Fire ignition • Inadvertent contact 	<ul style="list-style-type: none"> • Site risk assessment procedure • Circuit identification process • Safe approach distances • Plant clearance requirements • Access procedures • Code of practice training • Auditing process • First aid training • Rescue procedures and training • Safety observer posted • Personal protective clothing & Equip • Australian Standards AS5804.1, 5804.3 • VESI minimum rules for HV Live Work • System protection devices • Asset inspection • Communications process • Worksite security (traffic & pedestrian) • ENA Guidelines • Enterprise rules & guidelines • Lineworker training and qualifications • Refresher training • Procedures manual • Insulated plant equipment (EWP) • Regular equipment testing

Task / Activity	Hazards / Consequences	Control Measures
<p>Work on high voltage electrical apparatus (HV Live Work) Including single person aloft tasks</p>	<ul style="list-style-type: none"> • Death <ul style="list-style-type: none"> ○ Electrocution ○ Falls ○ Crushes • Serious injury • Electric shock • High voltage burns • Flashover • Induction • Damage to plant, equipment and assets • System feedback • Failure of plant, equipment and assets • Level of experience of Lineworker performing HV Live Work and operation of EWP. • Repetitive task injury • Adverse weather conditions • Fire ignition 	<ul style="list-style-type: none"> • HV Live Work training • HV Live Work refresher training • HV Live Work procedures manual • Australian Standards AS5804.1, 5804.2, 5804.3 • VESI minimum rules for HV Live Work. • Insulated HV Live Work equipment • Insulated plant equipment (EWP) • Safe approach distances • HV Live Work minimum approach distances • Manual Handling training. • Plant clearance requirements • Access procedures • Circuit identification process • First aid training • Rescue procedures and training • Site risk assessment procedure (including single person aloft aspects where required) • Safety observer posted • Code of practice training • Regular equipment inspection & testing • Personal protective clothing • System protection devices • Auditing process • National Transmission and Distribution Training Package. • Specific Plant training & licensing. • Organisational Heat Stress Policy. • Rotation of work roles. • Conductor loads and tensions established • Asset inspection • Communications process • Worksite security (traffic & pedestrian) • ENA Guidelines • Enterprise rules & guidelines

Using EWP's, Mobile Plant and Equipment in the vicinity of power lines	<ul style="list-style-type: none"> • Plant rollover • Plant contacting live assets • Traffic hazard in restricted area's • Damage to assets, plant and equipment • High voltage injection into low voltage assets • Flashover between EWP's • Fire ignition 	<ul style="list-style-type: none"> • Plant specific training and licensing • Plant set up requirements and Earthing including: <ul style="list-style-type: none"> ○ separation between plant • Conductor cover-up practices • Traffic management and training • Traffic management equipment • Auditing process • Highly manoeuvrable plant • Site risk assessment • Safe approach distances • Safety observer posted • First aid training • Rescue procedures and training • Regular electrical testing of plant • Code of practice training • Regular equipment inspection and or testing • Personal protective clothing • Australian Standards AS5804.1, 5804.2, 5804.3 • Step and Touch potential controls
--	--	--

NOTE: Listed activities above must be read in conjunction with each other, not in isolation.

The risk assessment and control measures table are based on the principals of the Australian Standards AS/NZS 4360 risk management.

Hazard / Risk Consequences:	The risk / hazards have been identified as being potentially serious.
Control Measures:	The control measures listed are mandatory and appropriate combinations shall be strongly implemented and followed so as to maximise the mitigation of the identified risks / hazards.
Residual Hazard / Risk:	HV Live Work and associated activities need to be continually monitored and managed as the implementation of the listed control measures render the risk / hazards as still being moderate.
Assessed:	VESI HV Live Work Committee

Appendix B - Guidelines for Using Hydraulic Tools in Direct Contact with Live HV Apparatus

1. Scope

This guideline outlines the minimum requirements for the use of hydraulic tools when they are used in direct contact with live HV apparatus and connected to the hydraulic tool outlets of an Elevating Work Platform (EWP) whilst undertaking HV Live Work (up to and including 33kV).

Only hydraulic tools meeting these requirements may be permitted to make contact with live apparatus.

All HV Live Work persons undertaking tasks where hydraulic equipment is to be used in direct contact with live apparatus shall be instructed in these procedures.

2. Hydraulic Tools

The hydraulic tools approved for use are Low pressure (up to 2000psi [140bar]):

- Hydraulic drills, impact wrenches
- Conductor crimping equipment
- Hydraulic cutters

Individual hydraulic tools shall be selected using a risk assessment process, which includes that tools must automatically release in the event of a malfunction or oil pressure loss.

Note: High pressure systems using intensifiers and oil pressures at around 10,000PSI are not recommended as a high amount of energy will be released into the surrounding environment in the event of a hose rupture.

3. System Operating Requirements

The system hydraulic configuration, pressure and hydraulic fluid flow rates from the EWP shall match the system requirements of the hydraulic tools being used (as per manufacturer/s specifications).

The hydraulic fluid reservoir shall be fitted with an approved hydraulic fluid moisture filter to ensure no moisture is transferred to the hydraulic fluid system. The hydraulic fluid moisture filter should be mounted to the “return” or low-pressure side of the hydraulic system.

The hydraulic hoses connecting the hydraulic tool from the EWP outlet shall be of an approved electrically insulating type and **shall be of a minimum length of 1 metre.**

4. System Electrical Testing Requirements

The electrical testing requirements for use of hydraulic tools from EWP outlets are outlined below;

5. Hydraulic Hoses

All hydraulic hoses shall be non-electrically conducting and not to exceed 3 metres in length.

The recommended testing intervals for hydraulic hoses is defined in IEC 62237.

All hydraulic hoses shall be electrically tested at the same time as the EWP boom is tested (at 6 monthly intervals).

All new/replacement hydraulic hoses shall undertake an initial electrical test prior to use in the field.

All new/replacement hydraulic hose assemblies shall undertake an initial pressure test prior to use in the field. The hose shall withstand 125 % of the rated working pressure.

Hydraulic hoses must be inspected prior to use and cleaned with an appropriate solvent as required.

6. Hydraulic Hose standards

All hydraulic hoses shall be selected to meet the anticipated working pressure requirements. Test reports from accredited laboratories should be used to aid verification of hydraulic hose performance.

7. Low Pressure Hose

The current Australian, IEC or SAE standards for hydraulic hoses do not make provision for suitably flexible non-conductive hose at the expected working pressures of 2250 PSI. This pressure requires hoses with a double synthetic braided construction.

Hydraulic hoses shall meet the electrical performance of category 100R6 in AS 3791 or current equivalent.

Hydraulic hoses shall meet the rupture performance of category 100R7 in AS 3791 or current equivalent.

Hose that have been identified as meeting these requirements are:

- Goodyear Saflex
- Nelphi Rubber Products B098

EWP vehicles must have a verification card or similar to indicate to users that the hydraulic system oil and hoses have undergone and passed the appropriate tests as outlined herein.

It is recommended that hydraulic equipment / tools be assigned to a specific vehicle and not interchanged between vehicles so as to not mix oil types and reduce the risk of oil contamination.

8. Hydraulic Fluid

8.1 Sampling

Samples of hydraulic fluid taken from the truck shall be taken from the pressure point coupling on the intended tool pressure line (installed before the return filter). The truck shall be exercised first for a minimum of 10 minutes to circulate all the oil so that it reaches operating temperature.

Suitable fittings shall be used to safely extract the oil sample. Prior to taking test samples, any fluid in the sample collection fitting should be drained into a separate container and disposed of.

Samples should be obtained directly into a clean, dry and sterile container made from a material that does not interact with or contaminate the sample. PVC containers are not recommended.

Samples should be promptly sealed to prevent the ingress of atmospheric moisture and not left exposed to sunlight.

The principles of fluid extraction listed Australian Standard 4002.2 (Extraction of fluid samples from an operating system) should also be used for further guidance.

8.2 Labelling of samples

Sample bottles should be labelled with the following information to aid identification:

Hydraulic Fluid Sample
<ul style="list-style-type: none">• Make and model• Registration number• Reservoir capacity• Sample date• Contact person & Telephone number• Relevant Material Safety Data / reference

8.3 Preliminary & Visual Examination

Hydraulic fluid shall be tested at 6 monthly intervals. All samples of hydraulic fluid (500 ml each sample) shall be visually examined for presence of free water and sediment such as insoluble sludge, carbon, fibres, dirt or metal particles. Should significant moisture/impurities be detected in the system, the fluid shall be replaced.

8.4 Dielectric Strength

While applicable to oils, whose primary function is to provide very high dielectric strength, the following standards provide further guidance on the conduct of oil testing.

- AS 1767.1. (Specification for unused mineral insulating oils for transformers and switchgear) and
- AS 1767.2.1 (Determination of the breakdown voltage at power frequency)

The dielectric strength of an insulating fluid is the minimum voltage at which electrical flashover occurs between two metallic electrodes. It indicates the ability of a fluid to withstand electrical stress. Low dielectric strength indicates contamination with water, carbon or other foreign matter. High dielectric strength is no indication that a fluid does not contain some contaminants. The contaminants causing low dielectric strength can usually be removed with an approved filter.

Dielectric strength is a 'must' on all fluids, new or used, because if the insulating value is not good, then the fluid is unfit for use, regardless of any other condition. The dielectric strength test does not give an indication as to the deteriorated conditions of a fluid. A fluid that is highly deteriorated will give a high dielectric strength value if dry and free from solid impurities.

8.5 Dielectric Strength Results

In evaluating a fluid in terms of dielectric strength test results, it should be remembered that the dielectric strength of a fluid is an index to good maintenance.

The average breakdown voltage obtained during the 6 tests* shall be greater than 20kV/cm.

*(Australian standard 1767.2.1 requires each fluid sample to undergo 6 individual tests and the results analysed in a specific manner.)

All replacement fluid shall be di-electrically tested as per above prior to use in the field.

Any significant degradation of the hydraulic fluid from previous electrical tests shall determine the need to replace the fluid.

8.6 Cleaning

Any hydraulic fluid spilled during the use of hydraulic tools shall be cleaned before the tool is to be used again on another job. An oil spill kit should be available.

Hydraulic hoses must be cleaned with an approved HV Live Work cleaner.

8.7 Flame Retardant Hydraulic Fluids

Flame retardant hydraulic fluids shall not be used, as most are water based.

8.8 Vacuum Exclusion Valves

Vacuum exclusion valves shall be fitted to the hydraulic circuit of all EWP's with a reach greater than 11 metres.

8.9 Hydraulic Oil Shutdown System

EWP's shall be fitted with hydraulic oil shutdown system to the hydraulic tool line to ensure that hydraulic fluid will immediately cease to flow in case of hose rupture etc. This shall be able to be operated from the basket aloft and from ground level.

Appendix C - VESI HV Live Work Crane Operator – Instructed Persons Checklist

This checklist is to enable the Person in Charge of the HV Live work to instruct a Crane Operator in the requirements of operating plant for a live conductor lift in conjunction with a HV live work team. The Crane Operator shall be directed by the nominated HV Live Worker at all times.

If these Requirements are not met, then work shall not proceed until the appropriate requirement/s is in place.

The instructed Crane Operator shall work to clearances (Exclusion Zone) as described in Table 1 which meets the requirements in the *Minimum Rules for carrying out High Voltage Live Work Section 10.4 HV Live Work Minimum Approach Distances*.

This checklist does not apply to a trained HV Live Worker who operates a Crane for live lifts, however it may be used as a reference, as it provides key safety information for the Crane Operator and the HV Live Work Team.

COMPANY DETAILS		
Crane Company		
Operator Name / Phone No.		
Company Contact Phone No.		
Item	Requirement	Yes, No
Crane Service provider details	Crane has current inspection records/certificates	
	Crane operator has applicable High-Risk Licence	
	Crane has load measuring device (with alarm preferred).	
Communication	Nominated HV Live Worker, Safety Observer and Dogman are identified to the crane operator.	
	Reliable and effective means of communication is established between the crane operator, nominated HV Live Worker and the Safety Observer.	
Operational information	Voltage level and exclusion zone distances in Table 1 explained to crane operator.	
	Confirm that all lifting equipment including all insulated equipment is tested and within test date.	
	Explain the effects on clearances from possible conductor movements such as conductor swing from wind loading, increase or decrease of sag from electrical loading or temperature changes.	
	Discuss how when lifting conductors, small movements can cause large increases in loadings on the conductor and adjacent structures. It is to be emphasised that conductors should only be moved to gain sufficient safe working clearances. Avoid the increase in conductor tension and vertical loading to avoid placing undue strain on conductors and support points.	
	Explain that the conductor height and loading (weight) has been determined and the conductor weights are to be monitored by the crane operator so determined loads are not exceeded (set alarm if available, operator to stop the lift if load is reached).	
	Has the crane been earthed or bonded to a permanent earth or temporary driven earth electrode as per section 8.17 VESI Minimum rules. Note: Lowering of an earth chain is not an adequate means of earthing when undertaking HV Live Work.	
Emergency preparedness.	Explain the hazards of step and touch potential to Crane Operator. Crane Operator is to be made aware that in the event of the crane coming inside the exclusion zone or making contact with conductors that they are not to exit the crane unless instructed or in an emergency. If it is necessary to leave the crane, turn off vehicle where it is safe to do so, assess the site and jump well clear keeping legs together at all times and avoid making simultaneous contact with the crane and ground. DO NOT STEP OFF , Hop away keeping both legs together or shuffle away for a distance of 10 metres from crane. DO NOT WALK .	
	Keep at least 10 metres clear of any grounded power lines and from the vehicle.	
Crane Operation	When operating near the exclusion zone, crane movements are to be kept to a minimum. The crane is to be operated in a slow and controlled manner.	
Risk Assessment	Crane Operator is to be inducted into and signed on to the Job Safety Assessment (JSA)	

Exclusion Zones for a Crane Operator under the Instruction of a HV Live Work Glove and Barrier / Stick Worker.

Table 1

Voltage level	Clearances		
	A Non-insulated Mobile Plant to an Uncovered Conductor	B Non-insulated Mobile Plant to a Covered Conductor	C Minimum Insulation Distance
22kV	700mm	400mm	700mm
66kV	900mm	600mm	900mm

The clearance in table 1 are from the crane and must be maintained at all times

Insulation Requirements

The insulation medium can be singular or multiple to create the minimum distance.

Diagram 1 - An insulating medium with a Minimum Insulation Distance Table 1 (Clearance “C”) shall be placed between the crane hook and the live conductors.

Diagram 2 - An insulation medium with a Minimum Insulation Distance Table 1 (Clearance “C”) shall be placed between;

1. the crane hook and the lifting beam, and
2. the lifting beam and the live conductors

Exclusion Zone Diagrams

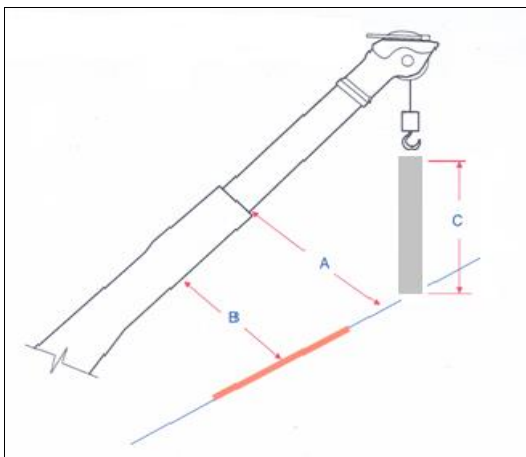

Diagram 1

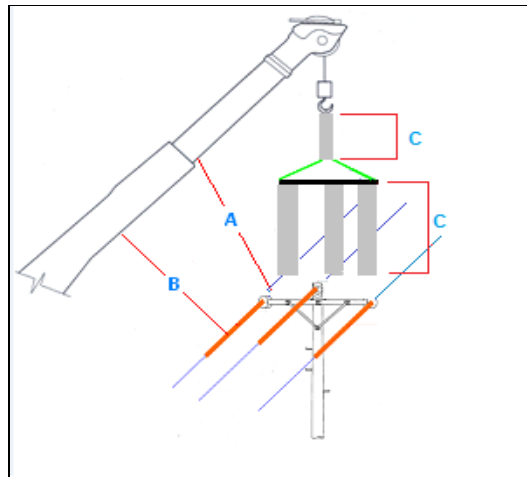

Diagram 2

	Print Name		Sign
Person in Charge			
Crane Operator			
Nominated Person			
Date	Issue Time	Cancellation Time	Application Number